

regom
instruments

flow & process solutions





Hygienic Single Seat Valves



RIEGER Hygienic single seat valves are used where a maximum of productivity, safety and quality is required. They can be found in plants of dairies, the food industry, the pharmaceutical and the chemical industries and in biotechnology.

The progressive valve program, thousand old proven in daily applications, enables high flexibility within the individual production series. This is why RIEGER Hygienic single seat valves ensure the perfect solution for our customers for their liquid products.

Due to the modular building system the change from hygienic to aseptic, from “air to open” to “air to close” is possible without problems. Also the installation dimensions can be customized to the givens in place.

Your advantages

Design	solid valve body, no dead spaces completely draining many built-in positions possible
Product safety	high-grade inner surfaces no dome or sump in product space
Maintenance	change of seals without special tools optimum cleanability
Efficiency	building block system standard seals low spare part costs

Technical Data

Material	product	1.4404/AISI316L
	contact	1.4435/AISI316L
	optional	1.4301/AISI304
	non product	
	contact	
Seals	O-rings	EPDM (Viton and other material upon request)
Temperatures maximum	operating temperature	130 °C
	sterilising temperature	150 °C* short-time (approx. 20 min)
Operating pressure	closing pressure	max. 6 bar
	Note:	see catalog pages
	Change over valves:	
	Actuator	min 6 bar -
	control air pressure	max. 10 bar
Surfaces	produktberührt	Ra <= 0,8 µm (32 µin)
	optional	electro polished, other surfaces upon request
	no product contact	Ra <=1,6 µm (64 µin)Tyü
Connections Standard pipes	DIN 11850-R2 (DIN 11866 A)	
	O.D.-Tube (DIN 11866 C)	
	DIN EN ISO 1127 (DIN 11866-B)	

* dependent upon operating conditions



3-A versions available

see 3-A certificate on website
www.rr-rieger.de





Hygienic Single Seat Valves



Hygienic Change Over Valve Type LL

pneumatic – air to open-spring to close NC – **one-piece valve body**

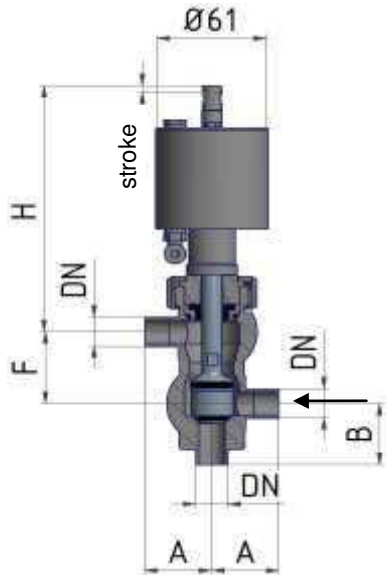

DIN	Pipe	A	B	H	F	Stroke	kg
10	13 x 1,5	40	40	158	42	10	2,7
15	19 x 1,5	40	40	161	47	10	2,7
20	23 x 1,5	45	40	165	45	10	2,8

NC = If air fails, lower port is closed.

Closing pressure of 6 bar is only ensured with flow direction into middle port with control air pressure of at least 6 bar (max. 10 bar) – see arrow.

Hygienic Change Over Valve Type LL

pneumatic – air to open-spring to close NC – **two-piece valve body**

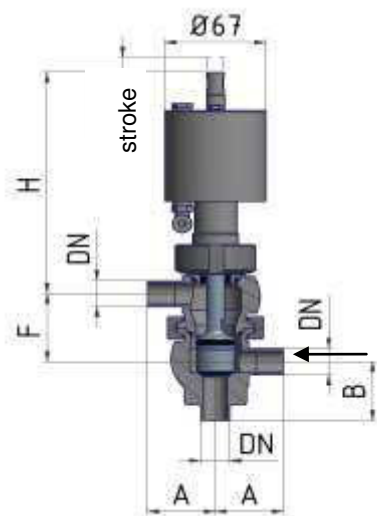

DIN	Pipe	A	B	H	F	Stroke	kg
10	13 x 1,5	40	40	158	42	10	2,7
15	19 x 1,5	40	40	161	47	10	2,7
20	23 x 1,5	45	40	165	45	10	2,8

NC = If air fails, lower port is closed.

Closing pressure of 6 bar is only ensured with flow direction into middle port with control air pressure of at least 6 bar (max. 10 bar) – see arrow.



Hygienic Single Seat Valves



Hygienic Change Over Valve Type LL

manual with crank handle – 3 ports – one-piece valve body

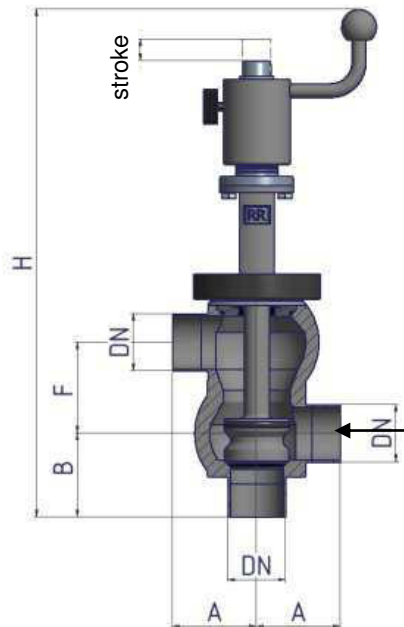

DN	Pipe	A	B	F	R	H	Stroke	kg
25	29 x 1,5	50	50	55	73	360	18	6,3
40	41 x 1,5	60	60	65	73	385	18	7,3
50	53 x 1,5	80	70	77	90	475	22	14,8
65	70 x 2	100	80	95	90	510	25	17,6
80	85 x 2	125	90	110	90	555	33	27,9
100	104 x 2	150	100	129	90	595	35	35,7
1"	25,4 x 1,65						18	6,3
1 1/2"	38,1 x 1,65		In case of order				18	7,3
2"	50,8 x 1,65		you get a 3D step file				22	14,8
2 1/2"	63,5 x 1,65		for your design department.				25	17,6
3"	76,2 x 1,65						33	27,9
4"	101,6 x 2,11						35	35,7

Closing pressure of 6 bar is only ensured with flow direction into middle port – see arrow.



Hygienic Single Seat Valves



Hygienic Change Over Valve Type LL

pneumatic – air to open-spring to close NC – **3 ports**– **one-piece valve body**

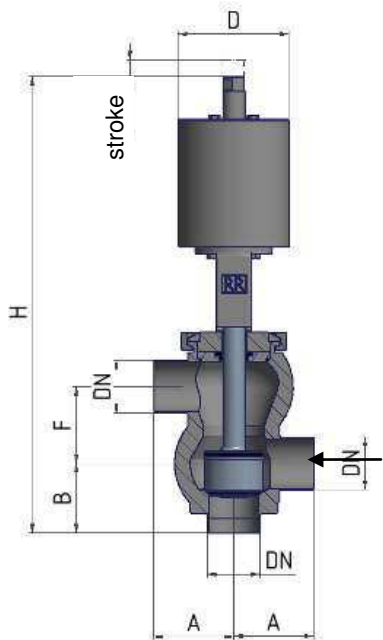

DN	Pipe	A	B	F	D	H	Stroke	kg
25	29 x 1,5	50	50	55	90	361	18	6,3
40	41 x 1,5	60	60	65	90	387	18	7,3
50	53 x 1,5	80	70	77	110	459	22	14,8
65	70 x 2	100	80	95	133	539	25	17,6
80	85 x 2	125	90	110	172	630	33	27,9
100	104 x 2	150	100	129	172	665	35	35,7
1"	25,4 x 1,65	In case of order					18	6,3
1 1/2"	38,1 x 1,65	you get a 3D step file					18	7,3
2"	50,8 x 1,65	for your design department.					22	14,8
2 1/2"	63,5 x 1,65	Drawing shows NC -					25	17,6
3"	76,2 x 1,65	NC = If air fails, lower					33	27,9
4"	101,6 x 2,11	port is closed.					35	35,7

Hygienic Change Over Valve Type LL

pneumatic – air to open-spring to close NC - **3 ports** – **two-piece valve body**

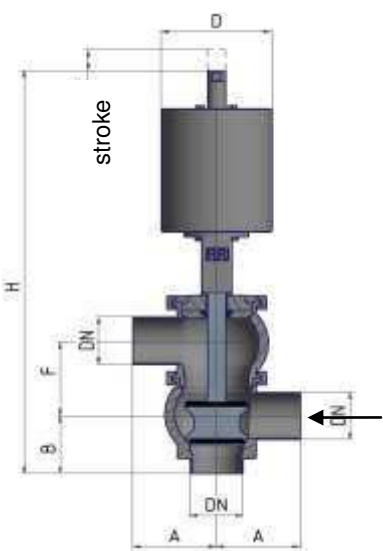

DN	Pipe	A	B	F	D	H	Stroke	kg
25	29 x 1,5	50	50	55	90	360	18	6,3
40	41 x 1,5	60	60	65	90	385	18	7,3
50	53 x 1,5	80	70	77	110	475	22	14,8
65	70 x 2	100	80	95	133	510	25	17,6
80	85 x 2	125	90	110	172	630	33	27,9
100	104 x 2	150	100	129	172	665	35	35,7
1"	25,4 x 1,65	In case of order					18	6,3
1 1/2"	38,1 x 1,65	you get a 3D step file					18	7,3
2"	50,8 x 1,65	for your design department.					22	14,8
2 1/2"	63,5 x 1,65	Drawing shows NC -					25	17,6
3"	76,2 x 1,65	NC = If air fails, lower					33	27,9
4"	101,6 x 2,11	port is closed.					35	35,7

Closing pressure of 6 bar is only ensured with flow direction into middle port with control air pressure of at least 6 bar (max. 10 bar) – see arrow.



Hygienic Single Seat Valves



Hygienic Change Over Valve Type TL

pneumatic – air to open-spring to close NC - 4 ports – one-piece valve body

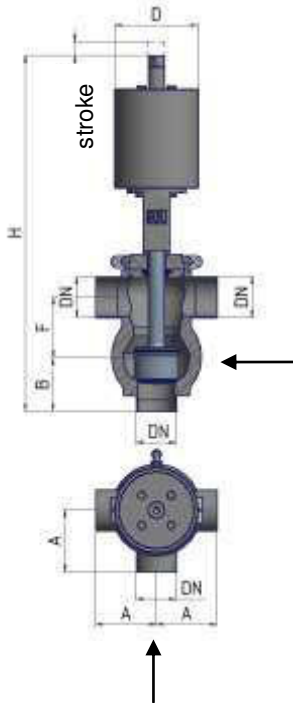

DN	Pipe	A	B	F	D	H	Stroke	kg
25	29 x 1,5	50	50	55	90	361	18	6,3
40	41 x 1,5	60	60	65	90	387	18	7,3
50	53 x 1,5	80	70	77	110	459	22	14,8
65	70 x 2	100	80	95	133	539	25	17,6
80	85 x 2	125	90	110	172	630	33	27,9
100	104 x 2	150	100	129	172	665	35	35,7
1"	25,4 x 1,65	In case of order					18	6,3
1 1/2"	38,1 x 1,65	you get a 3D step file					18	7,3
2"	50,8 x 1,65	for your design department.					22	14,8
2 1/2"	63,5 x 1,65	Drawing shows NC -					25	17,6
3"	76,2 x 1,65	NC = If air fails, lower					33	27,9
4"	101,6 x 2,11	port is closed.					35	35,7

Hygienic Change Over Valve Type TL

pneumatic – air to open-spring to close NC – 4 ports – two-piece valve body

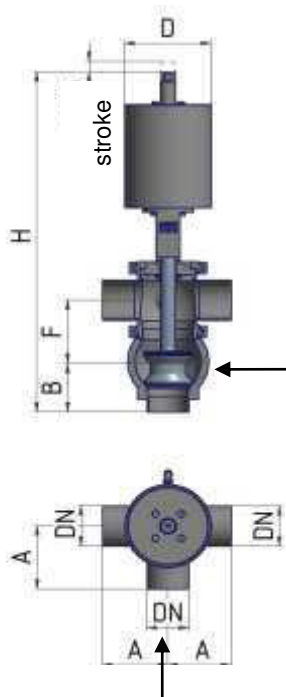

DN	Pipe	A	B	F	D	H	Stroke	kg
25	29 x 1,5	50	50	55	90	360	18	6,3
40	41 x 1,5	60	60	65	90	385	18	7,3
50	53 x 1,5	80	70	77	110	475	22	14,8
65	70 x 2	100	80	95	133	510	25	17,6
80	85 x 2	125	90	110	172	630	33	27,9
100	104 x 2	150	100	129	172	665	35	35,7
1"	25,4 x 1,65	In case of order					18	6,3
1 1/2"	38,1 x 1,65	you get a 3D step file					18	7,3
2"	50,8 x 1,65	for your design department.					22	14,8
2 1/2"	63,5 x 1,65	Drawing shows NC -					25	17,6
3"	76,2 x 1,65	NC = If air fails, lower					33	27,9
4"	101,6 x 2,11	port is closed.					35	35,7

Closing pressure of 6 bar is only ensured with flow TL direction into middle port with control air pressure of at least 6 bar (max. 10 bar) – see arrow.



Hygienic Mix Proof Valves



RIEGER-Hygienic mix proof valves guarantee reliable protection for your liquid product, as they completely separate non-compatible liquids. For years, they have been proven in plants of the beverage and brewery industries, of pharmaceutical as well as of food and dairy industries. The design of the one-part solid valve body and the radial sealing of both valve seats together with the balanced valve disks allow completely safe CIP/SIP-cleaning and so guarantee extremely high safety for your products. For further details concerning RIEGER-mix proof valves ask for our prospectus.

Your advantages

Design	one-piece valve body made from solid bar no weld torsion light: DN 100 only 35 kg only 4 seals in product space safe CIP/SIP-cleaning
Absolute product safety	vacuum safe: If vacuum in lower line a spring buffers vacuum in actuator. balanced valve disks radial sealing of both valve seats no impact between Valve disk and body – no need of impact buffering cylinder no soiling behind the O-rings
Serviceable maintenance	change of seals without special tools service without danger (spring in cage) service possible without compressed air low need of control air pressure DN 100: main stroke 7 l with 6 bar valve insert completely removable upwards easy cleaning by lifting of both disks
Efficiency	standard O-rings standard actuator with 2 lift functios fewest seal quantity on the market low water demand e.g. DN 65 KV-value cleaning 1,4 m³/h low pressure loss: 0 to 0,05 bar (0,8 psi)
Technical Data	
Material	in product contact 1.4404/AISI316L optional 1.4435/AISI316L non product contact 1.4301/AISI304
Seals	EPDM, Viton – other material upon request
Temperatures maximum	operating temperature 130°C* sterilization 150°C* short-time temperature (approx. 20 min)*
Operating pressure	closing tension N1, N3 max. 10 bar (145 psi) closing tension N5, N9 max. 4 bar (58 psi) on tank side; other 10 bar (145 psi) actuator air pressure min. 6 bar (87 psi) - max. 10 bar (145 psi) N1 water hammer safe up to 30 bar
Surfaces	in product contact Ra <= 0,8 µm (32 µin) non product contact Ra <= 1,6 µm (64 µin)



version N1



N2 PMO version
see page 26



*dependent upon operating conditions



Hygienic Mix Proof Valves



Hygienic Mix Proof Valve N1 DIN EHEDG

pneumatic – air to open-spring to close NC

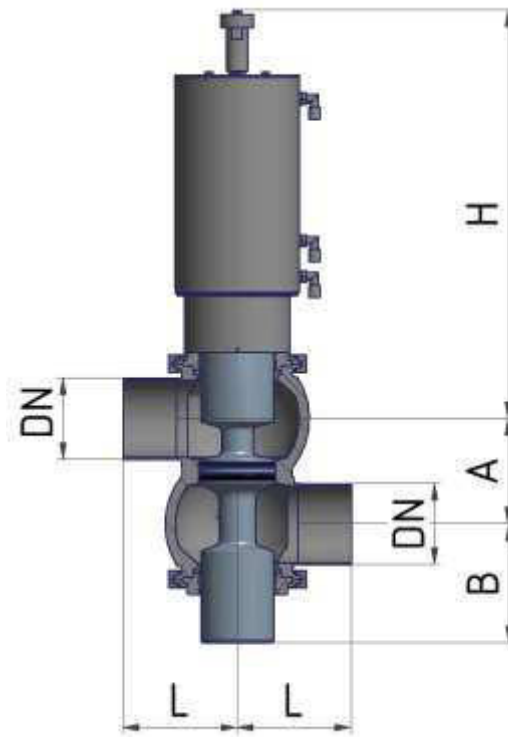

Valve body combinations



DIN	Pipe	A	B	L	H	kg
25	29 x 1,5	75	74	70	335	12
40	41 x 1,5	76	87	100	379	17
50	53 x 1,5	79	97	100	385	18
65	70 x 2	95	109	100	398	19
80	85 x 2	110	124	125	426	30
100	104 x 2	129	133	150	436	35
125	129 x 2	157	156	175	552	62
150	154 x 2	182	175	175	548	75
200	204 x 2	upon request				



Hygienic Mix Proof Valve N1 DIN reduced EHEDG

pneumatic – air to open-spring to close NC

Type 150 – upper body large – lower body small

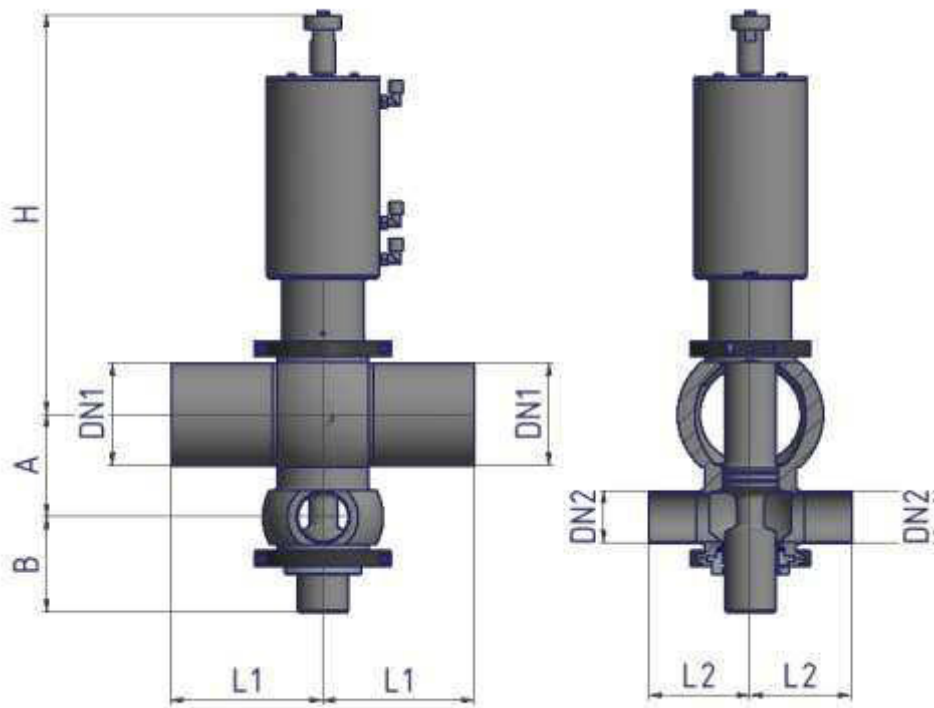

DN 1	DN 2	Pipe	A	B	L1	L2	H	kg
50	40	53x1,5 / 41x1,5	85	92	100	85	385	17,5
65	40	70x2 / 41x1,5	93	91	100	100	393	19,3
65	50	70x2 / 53x1,5	87	97	100	100	393	19,3
80	40	85x2 / 41x1,5	93	87	125	110	397	20,2
80	50	85x2 / 53x1,5	94,5	97	125	100	397	20,4
80	65	85x2 / 70x2	102,5	109	125	100	400	20,5
100	50	104x2 / 53x1,5	104	97	150	100	410	21,5
100	65	104x2 / 70x2	112	109	150	100	410	22,0
100	80	104x2 / 85x2	119,5	129	150	125	436	32,5
125	80	129x2 / 85x2	132	124	175	125	448	34,5
125	100	129x2 / 104x2	141,5	133	175	150	448	36,0

In case of order, your get a 3D step file for design department.
Installation dimensions for other combinations upon request



Hygienic Mix Proof Valve N1 DIN reduced EHEDG

pneumatic – air to open-spring to close NC

Type 200 – upper body small – lower body large

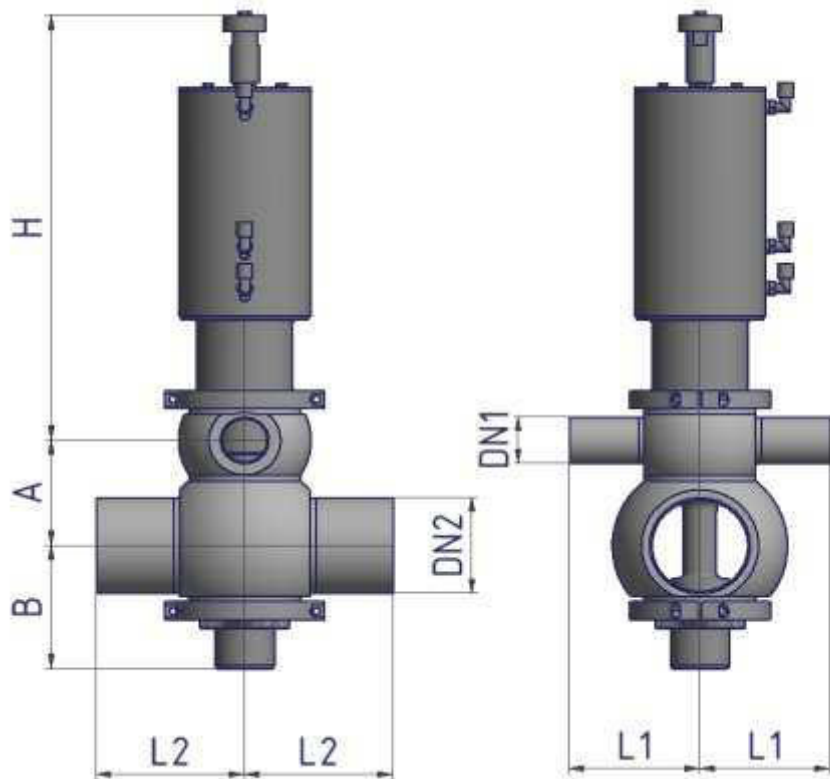

DN1	DN 2	Pipe	A	B	L1	L2	H	kg
25	50	29x1,5 / 53x1,5	67	97	118	100	400	18,0
25	65	29x1,5 / 70x2	87	105	100	100	385	19,3
40	65	41x1,5 / 70x2	93	105	100	100	379	19,4
40	80	41x1,5 / 85x2	93	109	110	125	379	20,7
50	80	53x1,5 / 85x2	100	110	100	125	384	19,6
65	80	70x2 / 85x2	102,5	117	100	125	397	20,8
65	100	70x2 / 104x2	112	127	100	150	397	21,0
80	100	85x2 / 104x2	119,5	132	125	150	426	32,9
80	125	85x2 / 129x2	132	144	125	175	426	33,0

In case of order, your get a 3D step file for your design department.
Installation dimensions for other combinations upon request



Hygienic Mix Proof Valves



Hygienic Mix Proof Valve N1 Inch 3-A Standard 85-02

pneumatic – air top open-spring to close NC

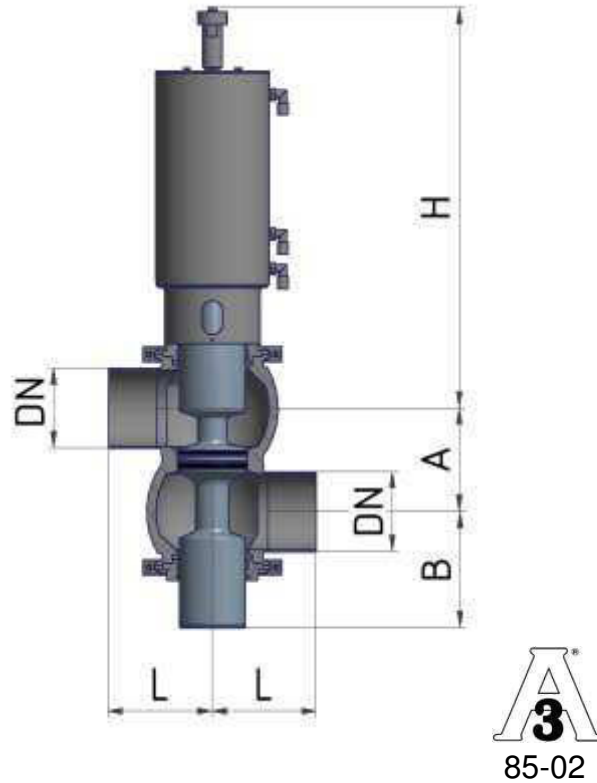

Valve body combinations



Inch	Pipe	A	B	L	H	kg
1"	25,4 x 1,65	78,5	73	100	333	12
1 1/2"	38,1 x 1,65	79	85	100	378	17
2"	50,8 x 1,65	81,5	96	100	384	18
2 1/2"	63,5 x 1,65	100	107	100	394	19
3"	76,2 x 1,65	118	130	125	422	30
4"	101,6 x 2,11	131	132	150	435	35
6"		upon request				75



Hygienic Mix Proof Valves



Hygienic Mix Proof Valve N1 reduced in Inch 3-A Standard 85-02

pneumatic – air top open-spring to close NC

Type 150 – upper body large – lower body small

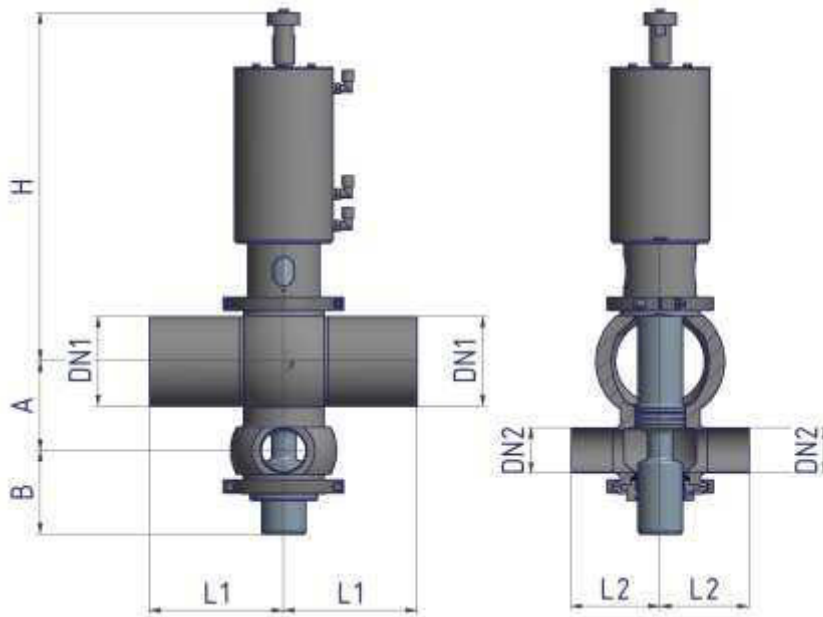

Type 200 – upper body small – lower body large

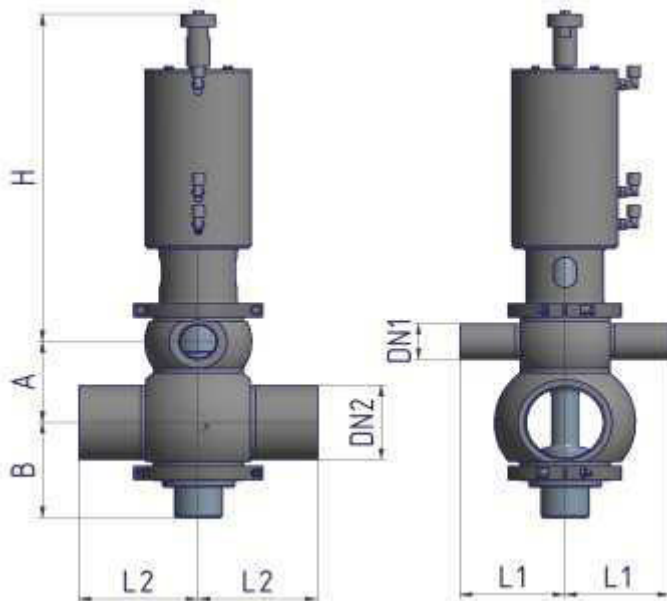

Dimensions and prices upon request



Hygienic Mix Proof Valves



Hygienic Mix Proof Valve N2 DIN PMO 3-A Standard 85-02

pneumatic – air top open-spring to close NC

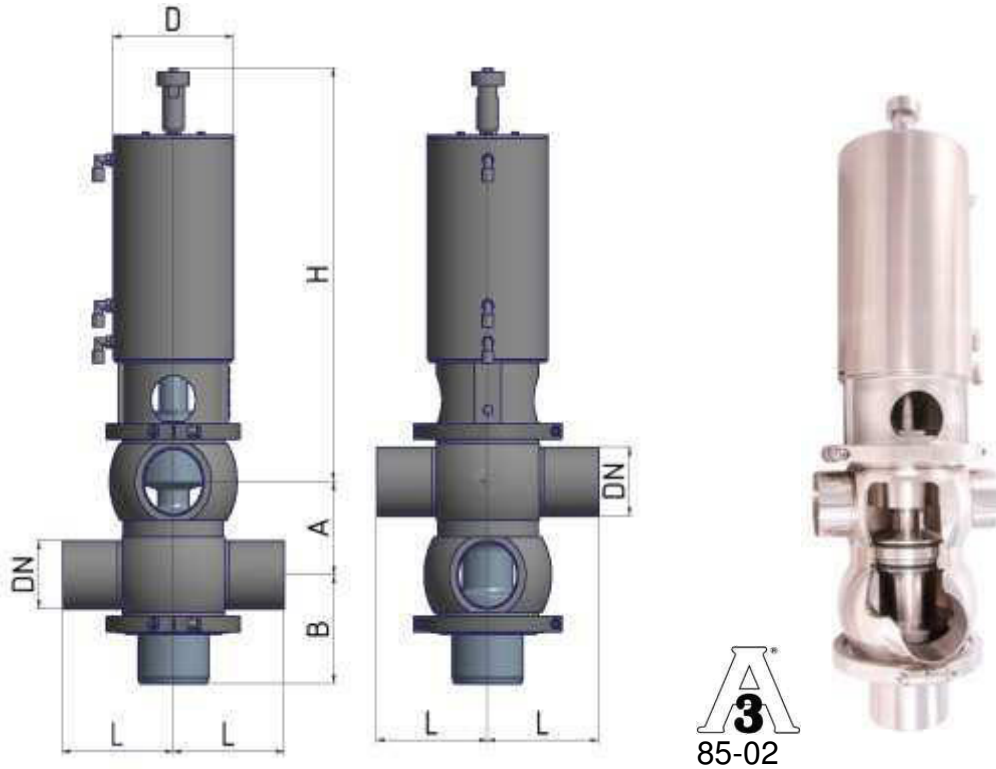

Valve body combinations



DIN	Pipe	A	B	L	H	Stroke	kg
40	41 x 1,5	76	86	100	385	33	17
50	53 x 1,5	81	97	125	390	35	18
65	70 x 2	95	114	125	420	40	19
80	85 x 2	110	116	150	427	44	30
100	104 x 2	129	141	175	525	54	35
125	129 x 2	157	160	175	535	54	62



Hygienic Mix Proof Valves



Hygienic Mix Proof Valve N2 Inch PMO 3-A Standard 85-02

pneumatic – air top open-spring to close NC

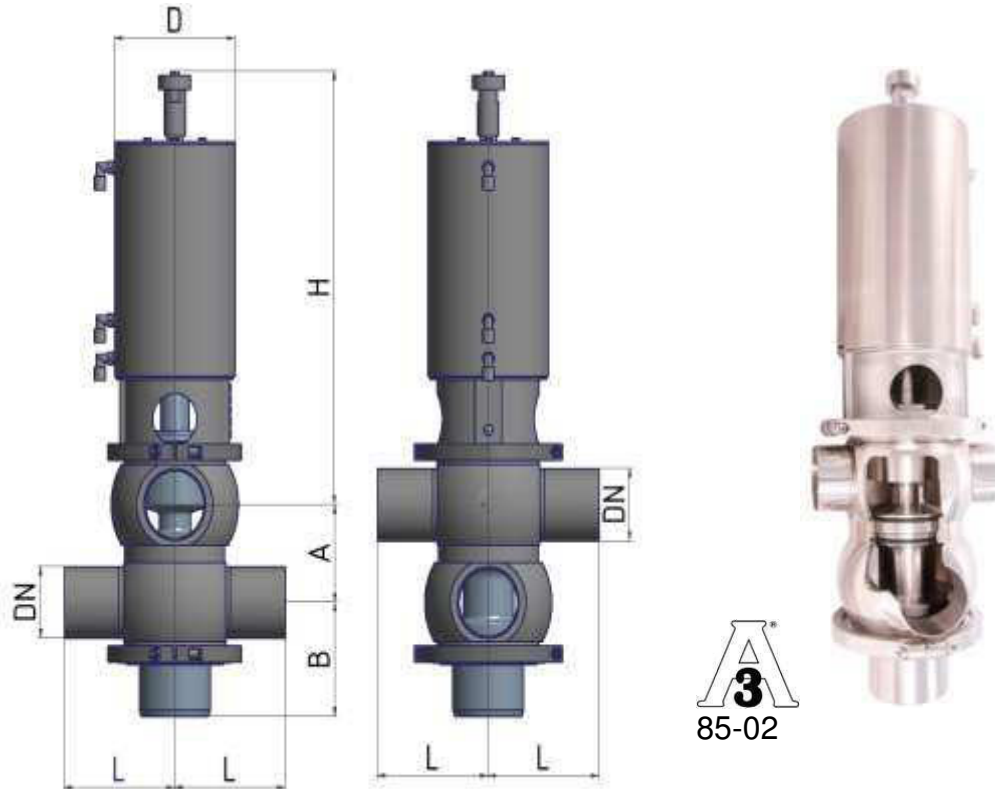

Valve body combinations



Inch	Pipe	A	B	L	H	Stroke	kg
1 1/2"	38,1 x 1,65	79	85	100	382	33	17
2"	50,8 x 1,65	83	97	125	388	35	18
2 1/2"	63,5 x 1,65	100	111	125	417	40	19
3"	76,2 x 1,65	118	112	150	425	44	30
4"	101,6 x 2,11	129	142	175	525	54	35



Hygienic Mix Proof Change-Over Valve N3 DIN

pneumatic – air top open-spring to close NC – type N3.01.001 – two-piece body

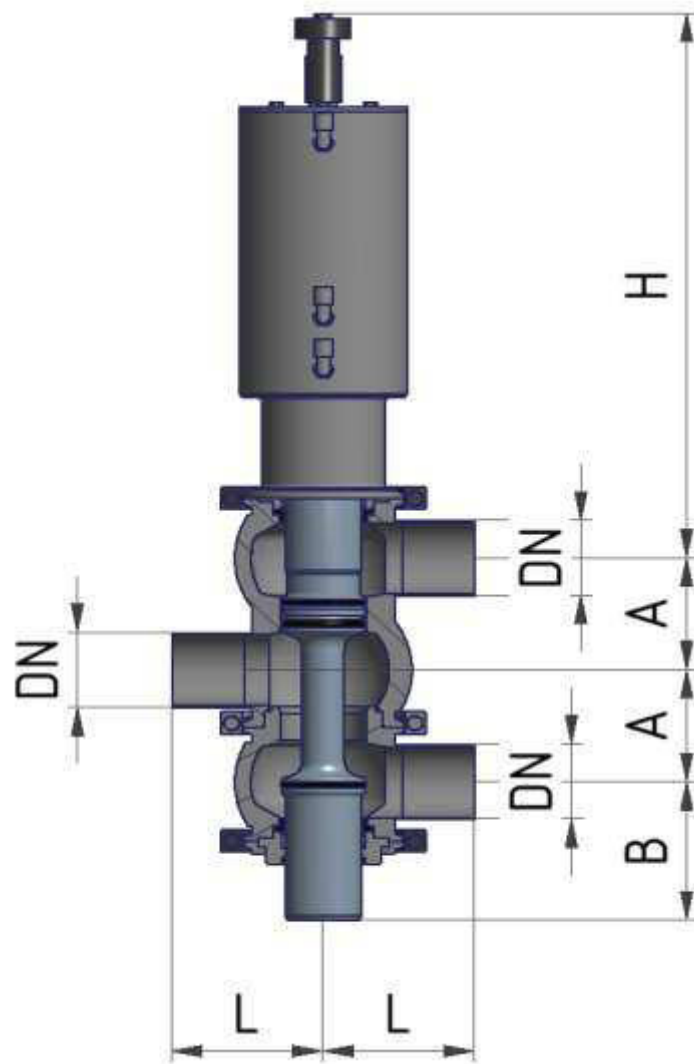

DN	Pipe	A	B	L	H
25	29 x 1,5	75	74	70	335
40	41 x 1,5	76	87	100	379
50	53 x 1,5	79	97	100	385
65	70 x 2	95	109	100	393
80	85 x 2	110	124	125	426
100	104 x 2	129	133	150	436
125	129 x 2	157	156	175	552
150	154 x 2	182	175	175	548



Hygienic Mix Proof Change-Over Valve N3 Inch

pneumatic – air top open-spring to close NC - type N3.01.001 – two-piece body

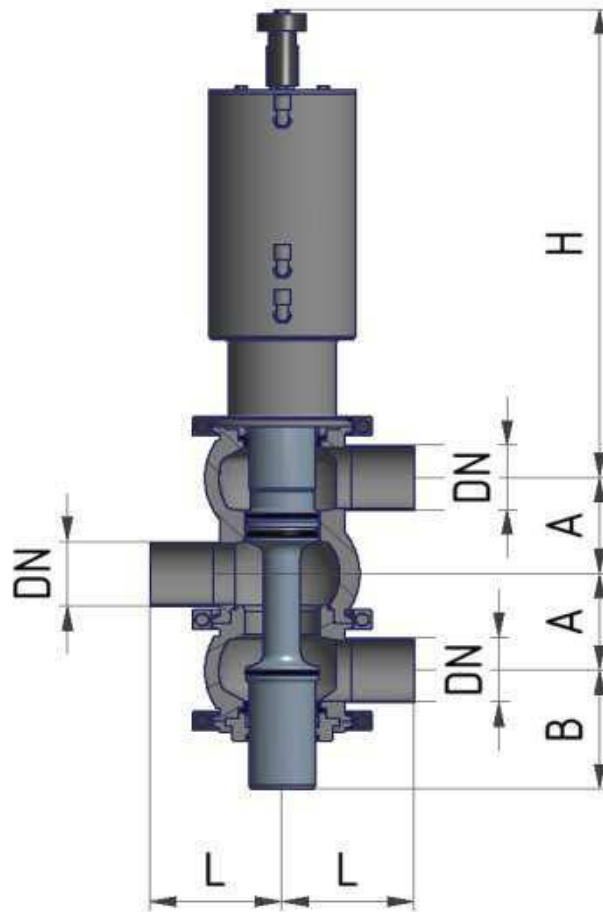

Inch	Pipe	A	B	L	H
1"	25,4 x 1,65	78,5	72,5	100	333
1 1/2"	38,1 x 1,65	79	85	100	378
2"	50,8 x 1,65	81,5	96	100	384
2 1/2"	63,5 x 1,65	100	107	100	394
3"	76,2 x 1,65	118	130	125	422
4"	101,6 x 2,11	131	132	150	435

In case of order you get a 3D step file for your design department.



Hygienic Mix Proof Change-Over Valve N3 Inch

pneumatic – air top open-spring to close NC - type N3.01.300 – three-piece body

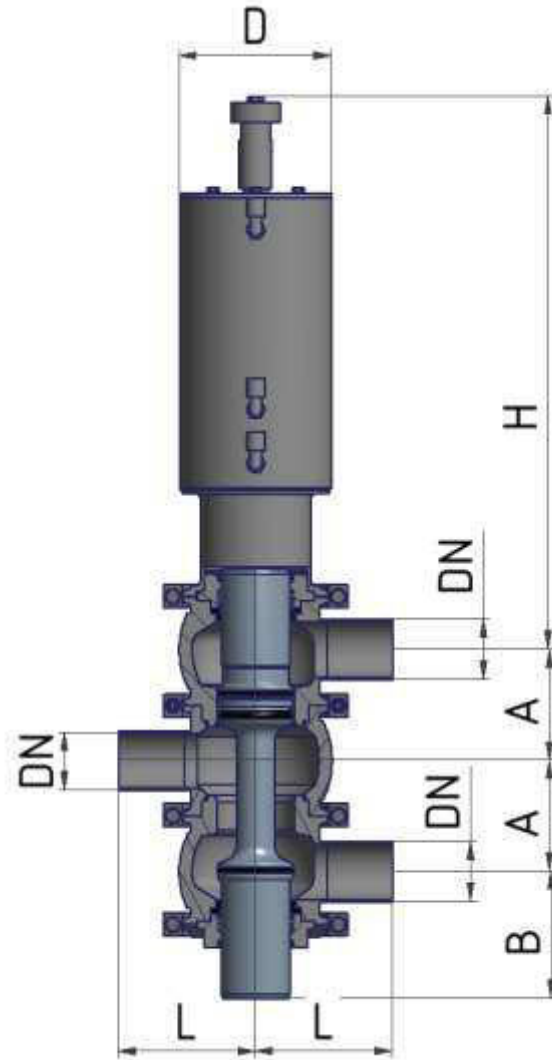

Inch	Pipe	A	B	L	H
1"	25,4 x 1,65	78,5	72,5	100	333
1 1/2"	38,1 x 1,65	79	85	100	378
2"	50,8 x 1,65	81,5	96	100	384
2 1/2"	63,5 x 1,65	100	107	100	394
3"	76,2 x 1,65	118	130	125	422
4"	101,6 x 2,11	131	132	150	435

In case of order you get a 3D step file for your design department.



Hygienic Mix Proof Bottom Seat Valve N5 DIN

pneumatic – air top open-spring to close NC - type N5.02.250

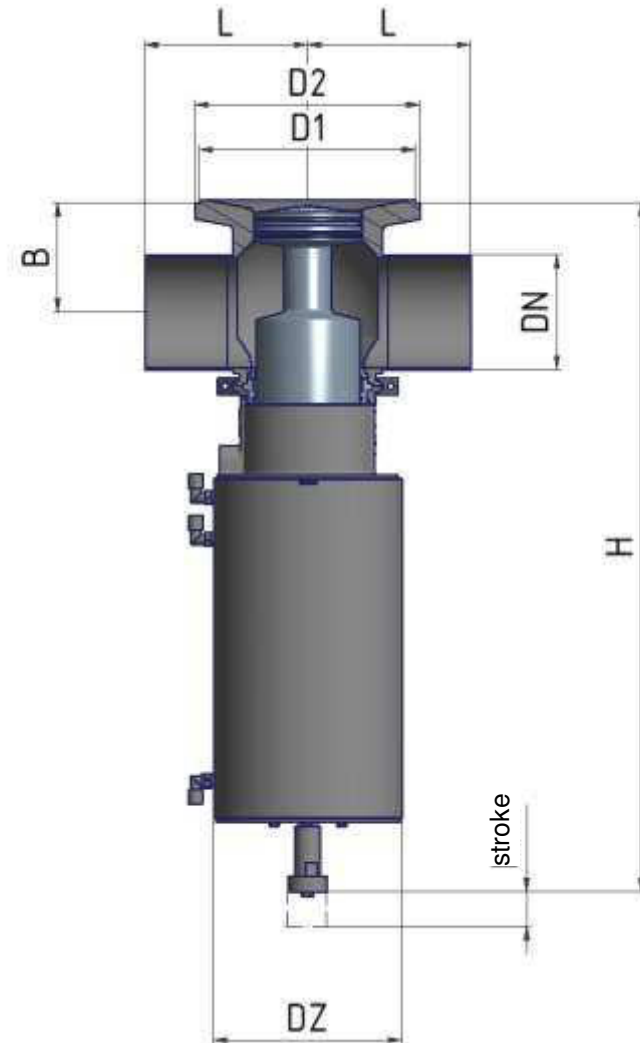

DIN	Stroke	Pipe	H	B	D1	D2	DZ	L	kg
25		29 x 1,5	upon request				111	100	12
40		41 x 1,5	upon request				111	100	16
50	34	53 x 1,5	440	59	138	146	111	100	17
65	38	70 x 2	458	68	150	158	111	100	19,5
80	45	85 x 2	518	84,5	170	178	136	125	28
100	45	104 x 2	630	103	200	208	174	150	45

In case of order you get a 3D step file for your design department.
Upon request valve body also available with only 1 port.



Hygienic Mix Proof Bottom Seat Valve N5 Inch

pneumatic – air top open-spring to close NC - type N5.02.250

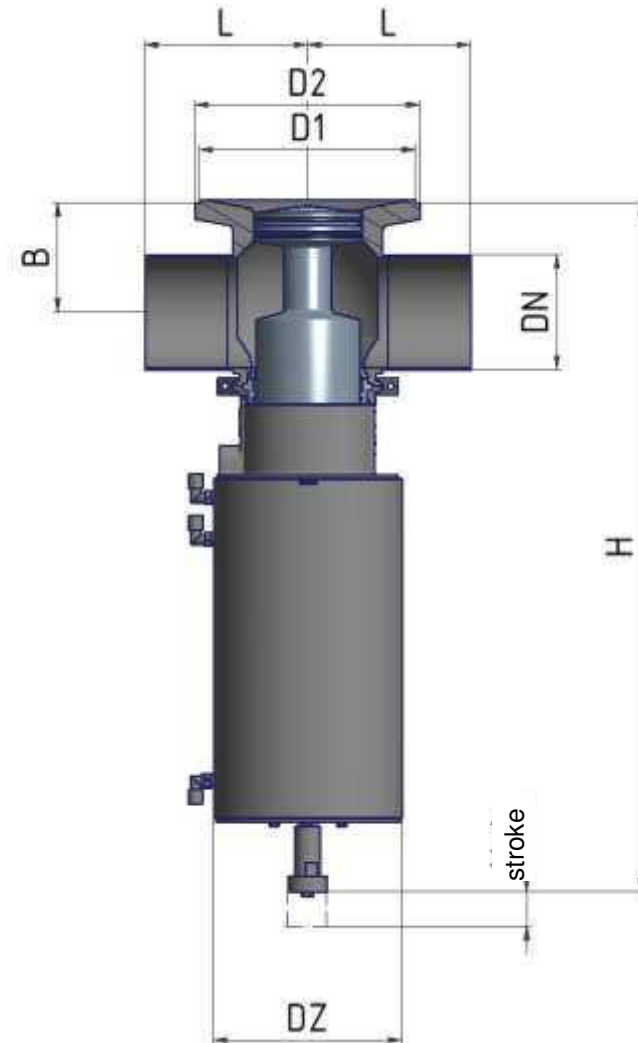

Inch	Stroke	Pipe	H	B	D1	D2	DZ	L	kg
1 ½"	34	38,1 x 1,65	443	65,5	125	133	111	100	16
2"	34	50,8 x 1,65	444	60,5	125	133	111	100	17
2 ½"	38	63,5 x 1,65	461	71	125	158	111	100	19,5
3"	45	76,2 x 1,65	521	88,5	170	178	136	125	28
4"	45	101,6 x 2,11	633	104	200	208	170	150	45

In case of order you get a 3D step file for your design department.
Upon request valve body also available with only 1 port.



Hygienic Mix Proof Bottom Seat Change-Over Valve N9 DIN

pneumatic – air top open-spring to close NC – type N9.01.001
tank connection: turned on weld-in flange

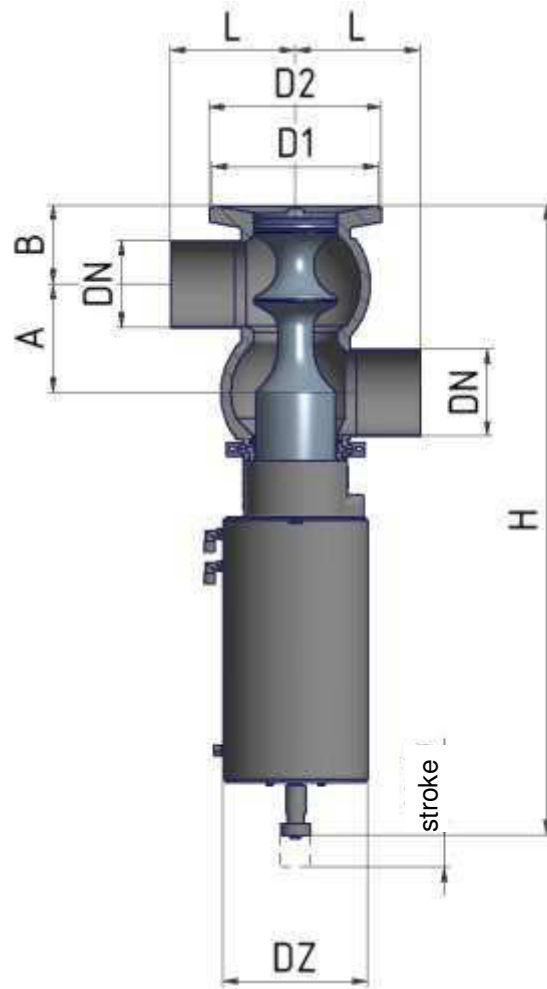

DIN	Stroke	Pipe	H	A	B	D1	D2	DZ	L
40	33	41 x 1,5	509	76	54	138	146	111	100
50	34	53 x 1,5	550	79	59	138	146	108	100
65	38	70 x 2	611	95	68	150	158	108	100
80	45	85 x 2	670	110	84,5	170	178	132	125
100	45	104 x 2	753	129	94	200	208	174	150

In case of order you get a 3D step file for your design department.



Hygienic Mix Proof Bottom Seat Change-Over Valve N9 DIN

pneumatic – air top open-spring to close NC – type N9.01.150
tank connection: weld end

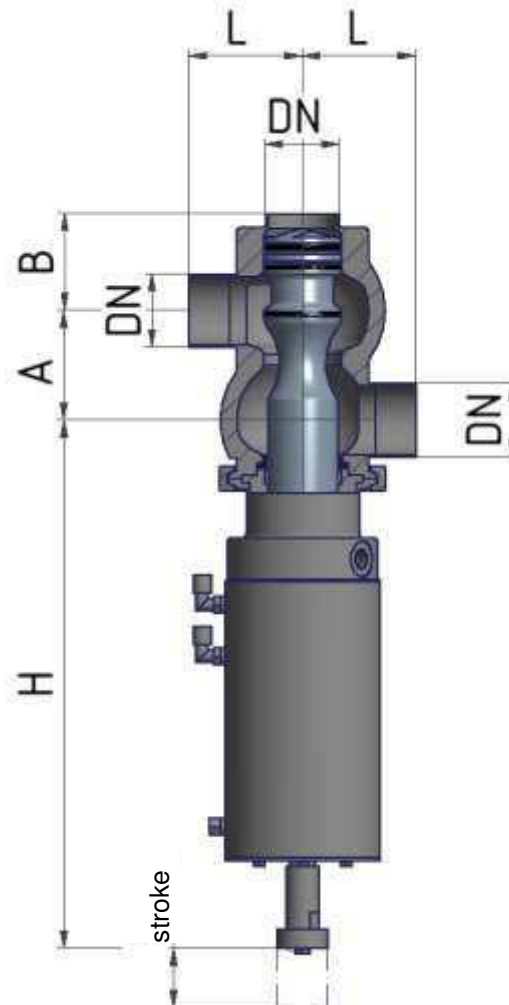

DIN	Stroke	Pipe	H	A	B	L
40	26	41 x 1,5	380	79	60	85
50	34	53 x 1,5	385	79	70	100
65	38	70 x 2	393	95	85	100
80	45	85 x 2	436	110	120	125
100	44	104 x 2	530	129	128	150

In case of order you get a 3D step file for your design department.



Hygienic Mix Proof Bottom Seat Change-Over Valve N9 DIN

pneumatic – air top open-spring to close NC – type N9.01.200

tank connection: separate weld-in flange

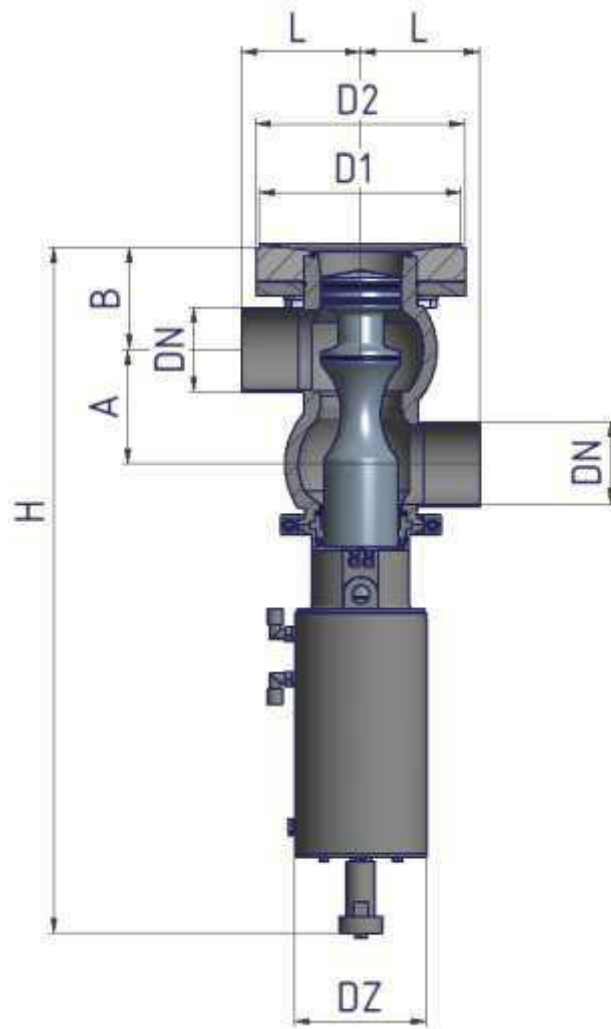

DIN	Stroke	Pipe	H	A	B	D1	D2	DZ	L	kg
										without flange
50										
65	38	70 x 2	614	95	85	170	176	111	100	24
80	45	85 x 2	685	110	92	200	209	136	125	27
100										

In case of order you get a 3D step file for your design department..



Hygienic Mix Proof Bottom Seat Change-Over Valve N9 Inch

pneumatic – air top open-spring to close NC – type N9.01.001

tank connection: turned on weld-in flange

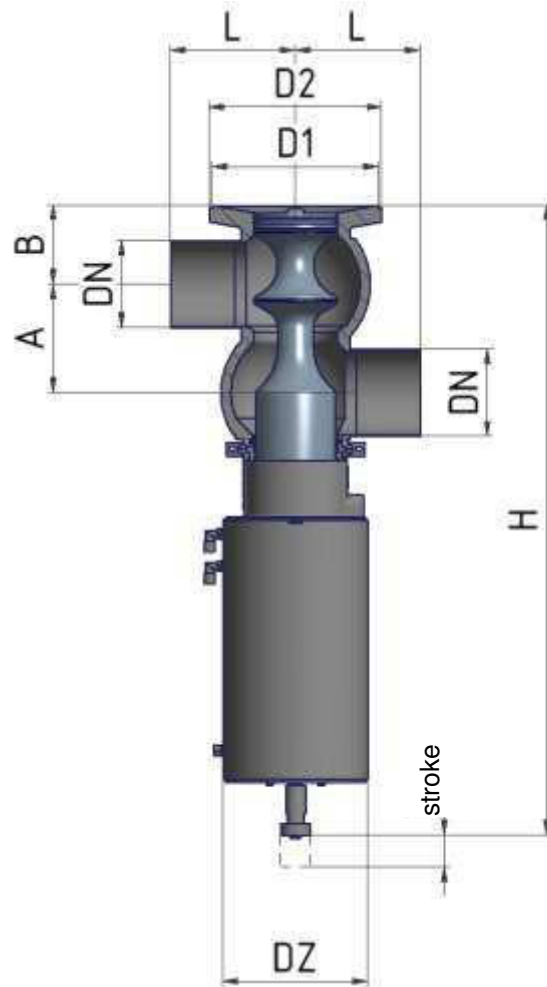

Inch	Stroke	Pipe	H	A	B	D1	D2	DZ	L
1 ½"	33	38,1 x 1,65	509	79	52,5	138	146	111	100
2"	34	50,8 x 1,65	550	81,5	60,5	138	146	111	100
2 ½"	38	63,5 x 1,65	611	100	71	150	158	111	100
3"	45	76,2 x 1,65	670	118	88,5	170	178	132	125
4"	45	101,6x2,11	753	131	104	200	208	174	150

In case of order you get a 3D step file for your design department.



Hygienic Mix Proof Bottom Seat Change-Over Valve N9 Inch

pneumatic – air top open-spring to close NC – type N9.01.150
tank connection: weld end

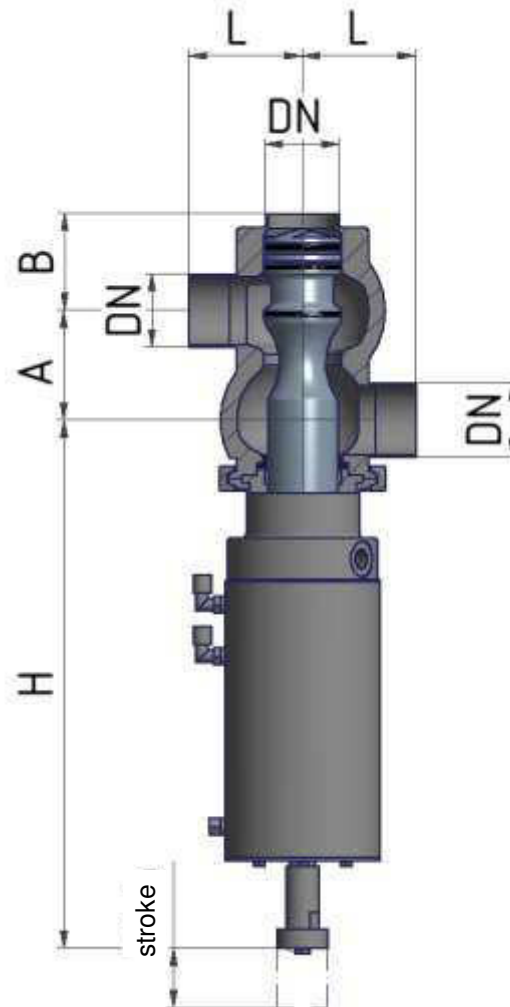

Inch	Stroke	Pipe	H	A	B	L
1 1/2"	26	38,1 x 1,65	378	79	70	100
2"	34	50,8 x 1,65	384	81,5	69	100
2 1/2"	38	63,5 x 1,65	390	100	83	100
3"	45	76,2 x 1,65	432	118	116	125
4"	44	101,6x2,11	529	131	127	150

In case of order you get a 3D step file for your design department.



Hygienic Mix Proof Bottom Seat Change-Over Valve N9 Inch

pneumatic – air top open-spring to close NC – type N9.01.200

tank connection: separate weld-in flange

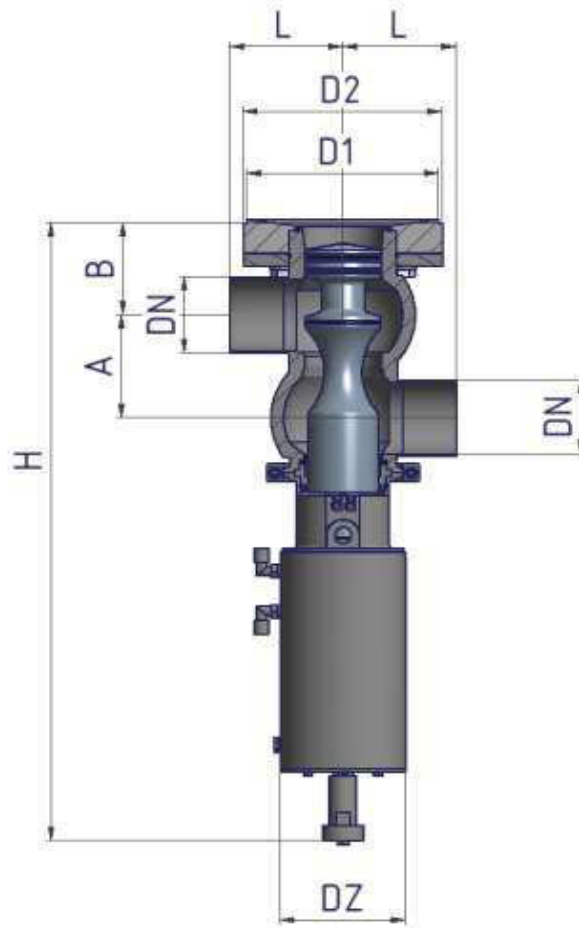

Inch	Stroke	Pipe	H	A	B	D1	D2	DZ	L	kg
										without flange
2"		50,8 x 1,65								
2 ½"	38	63,5 x 1,65	614	100	86	170	176	111	100	24
3"	45	76,2 x 1,65	685	118	90,5	200	209	136	125	27
4"		101,6x2,11								

In case of order you get a 3D step file for your design department.



Leakage Drain

for leakage ports



Inch	Reference Number	Price	
3/8"	5030038	56 €	
A	B	C	D
3/8"	12 x 1,5	71,5	100

not discountable



Double Seal Valves



RIEGER Double seal valves are used for reliable separation of liquid products from cleaning agents in pipes. They are the link between leakage butterfly valve and mix proof valve. Both seats are directly combined like in the leakage butterfly valve. But it is a right angel valve with ball body which complies with the hygienic requirements. The leakage space is situated between the separating gaskets. The leakage fluid is drained off through the leakage valve. Optional, also a rinsing CIP valve is available. The design of the one-piece solid and dead space free valve body guarantees optimal CIP/CIP cleaning possibilities. The valves are applied in plants of breweries, beverages, dairies and food industries.

Your benefits

Design	one-piece solid valve body no dead space safe CIP/SIP cleaning
Absolute product safety	radial sealing of valve disks safe separation of products leakage is safely drained off
Serviceable maintenance	change of seals without special tools valve insert completely removable upwards
Efficiency	standard O-rings few seals low spare part costs



Technical Data

Material	in product contact	1.4404/AISI316L
	optional	1.4435/AISI316L
	non product contact	1.4301/AISI304
Seals	O-rings	EPDM; Viton and others upon request
Temperatures maximum	operating temperature	up to 130 °C*
	sterilization temperature	up to 150 °C* short-time (approx. 20 min)
Operating pressure	closing pressure	max. 6 bar
	control air pressure	min 6 bar - max. 10 bar
Surfaces	in product contact	Ra <= 0,8 µm
	optional	electro polished, other surfaces upon request
	non product contact	Ra <=1,6 µm
Connections Standard pipe classes	DIN 11850-R2 (DIN 11866 A) O.D. tube (DIN 11866 C)	

*depending on operating conditions



Double Seal Valves



D31.01.100 with 2 CIP valves

pneumatic – air to open-spring to close NC – with straight CIP tubes

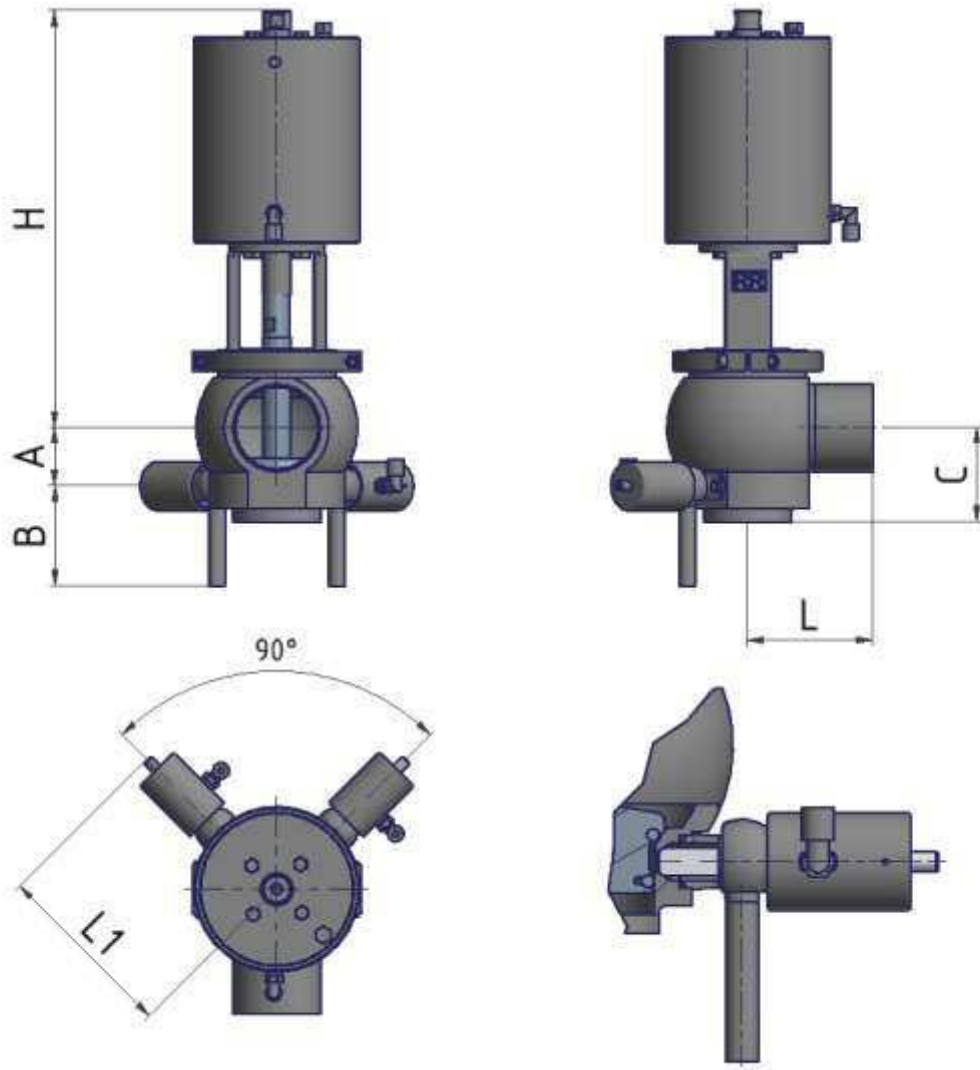



Double Seal Valves



DD31.01.200 with 2 CIP valves

pneumatic – air to open-spring to close NC – with bent CIP tubes

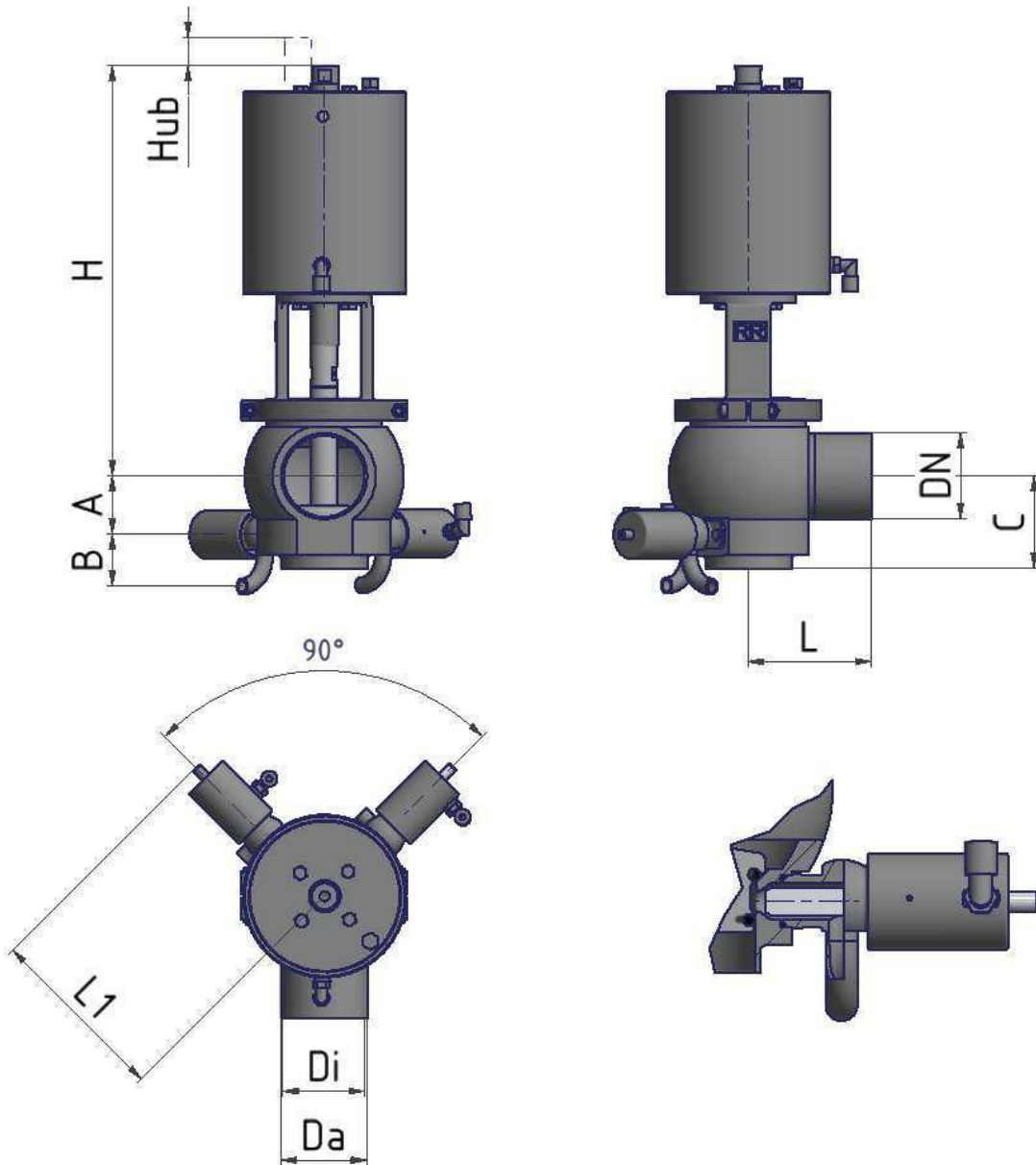



Double Seal Valves



RIEGER Double seal valves N4 piggable guarantee reliable protection for your product, as they completely separate non-compatible liquids. They have been proven in plants of the beverage and brewery industries, as well as of food and dairy industries.

The design of the one-piece solid valve body and the two radial seals of both valve seats together with the balanced valve disk allow completely safe CIP/SIP cleaning and so guarantee extremely high safety for your products.

Your benefits

Design	one-part valve body made of solid bar no weld torsion in product space only 3 seals safe CIP/SIP cleaning
Absolute product safety	radial sealing of both valve seats balanced valve disk easy cleaning by lifting of both valve seats in both directions
Serviceable maintenance	exchange of gaskets without special tools low need of control air pressure valve insert completely removable upwards
Efficiency	Standard O-rings Standard actuator with 2 lift functions few gaskets minimal maintenance costs piggable



Technical Data

Material	in product contact non product contact	1.4404/AISI316L 1.4435/AISI316L 1.4301/AISI304
Seals	EPDM and PEEK	other materials upon request e.g. Viton
Temperatures maximum	operating temperature sterilization temperature	up to 130 °C* up to 150 °C* short-time (approx. 20 min)
Operating pressure	closing pressure in upper line in lower pigging line control air pressure	6 bar maximum see dimensional sheet min. 6 bar - max. 10 bar up to 30 bar
Surfaces	water hammer safe product contact optional non product contact	Ra <= 0,8 µm electro polished, other surfaces upon request Ra <=1,6 µm

Valve under utility model status!

also available in 3-A version see page 16 and 17



*dependent on operating conditions



Double Seal Valves

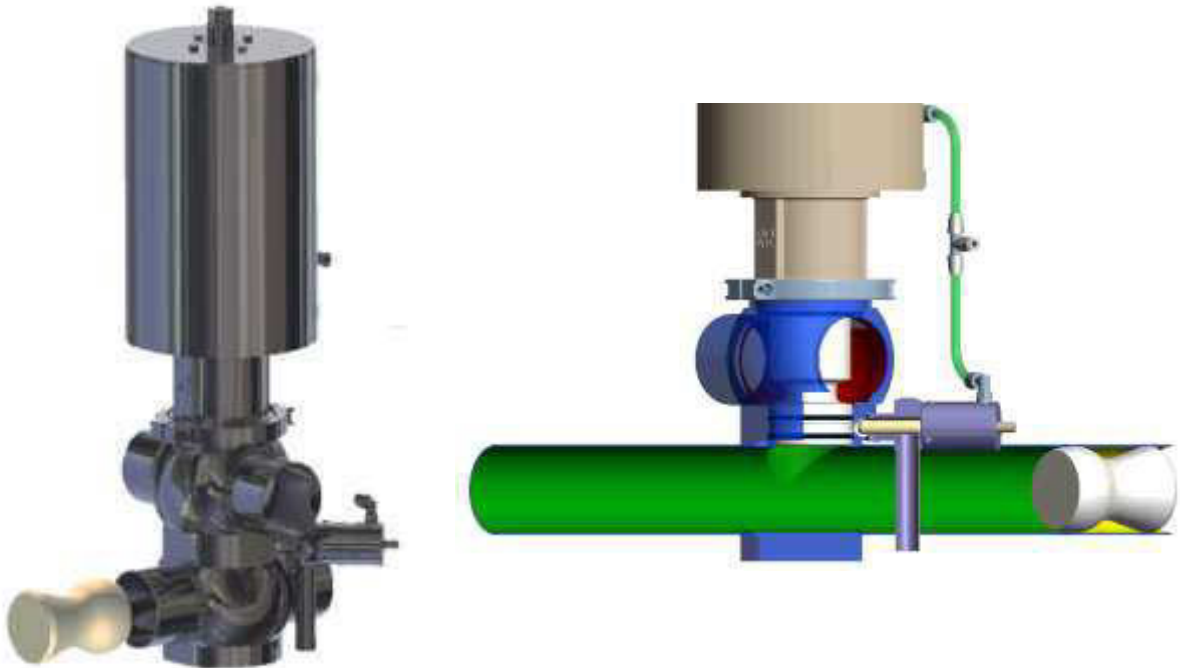

- maximum product efficiency
- low waste water costs and environmental burden
- reduced cleaning periods and costs
- minimization of cleaning water consumption
- minimization of cleaning agent consumption



switching between
main and CIP valve





Double seal valve N4 – piggable - DIN

pneumatic – air to open-spring to close NC

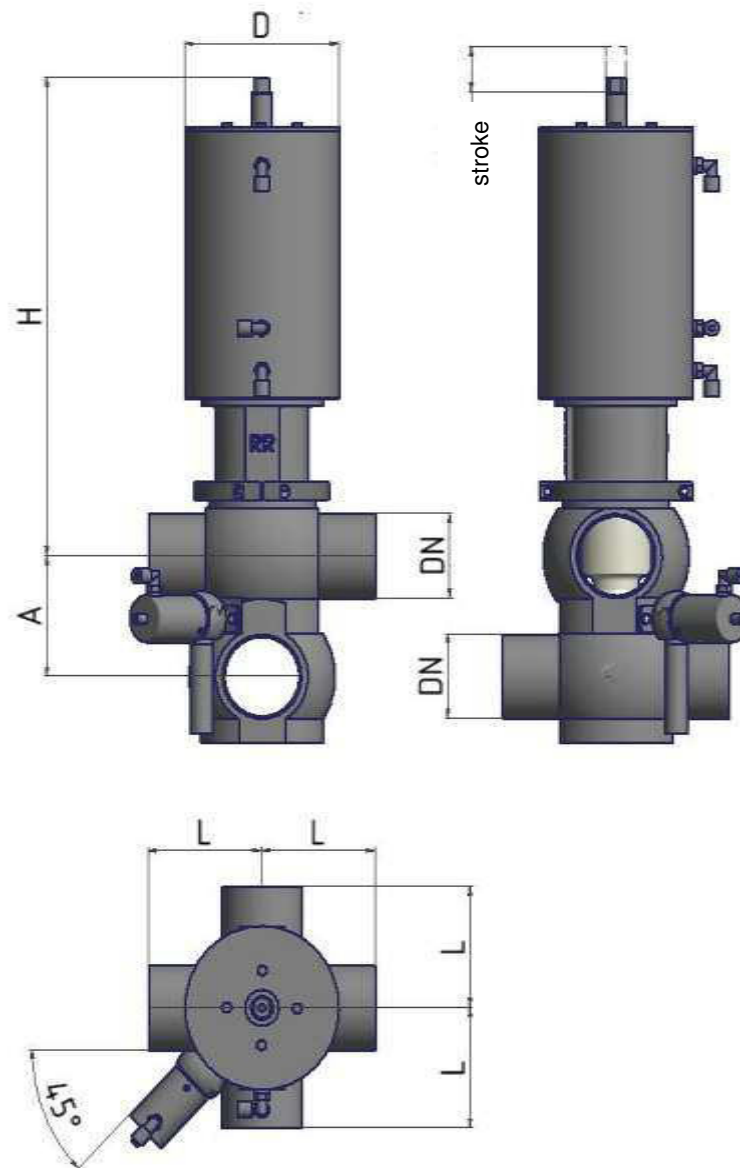

DIN	Pipe	A	L	H	D	Stroke	max. bar in pigging line	kg
40	41 x 1,5	72	100	352	110	42	13	
50	53 x 1,5	84	100	358	110	42	8,5	25
65	70 x 2	100	100	397	136	45	9	26
80	85 x 2	115	125	440	174	46	10	39
100	104 x 2	134	150	450	174	46	7	



Double Seal Valves



Double seal valve N4 – piggable - Inch 3-A standard 53-06

pneumatic – air to open-spring to close NC

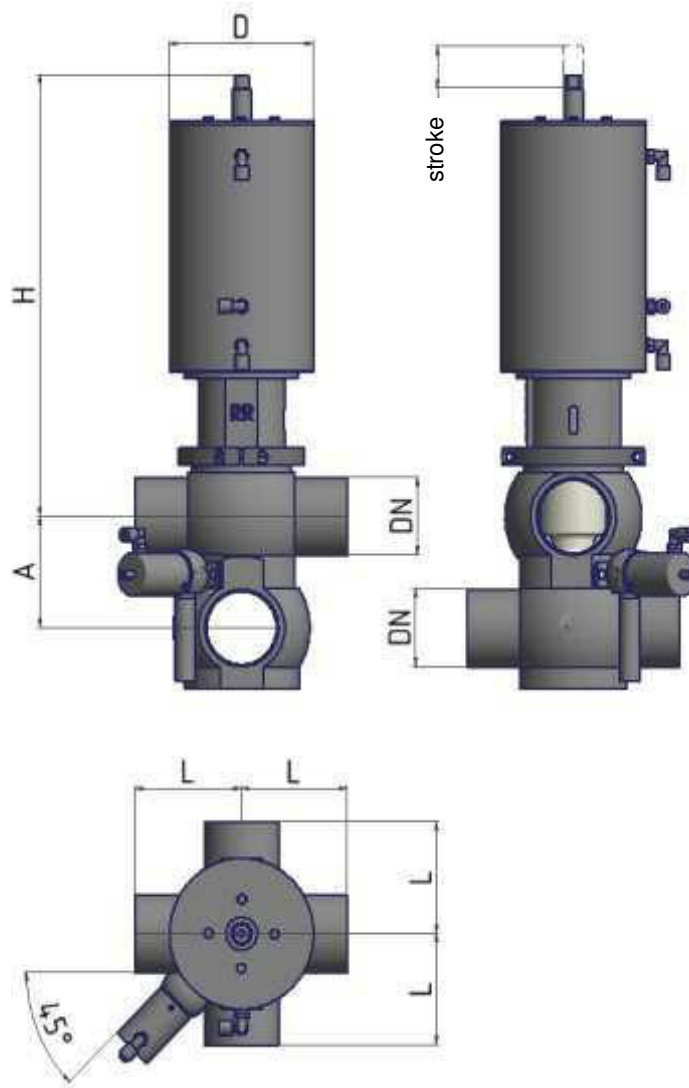

Inch	Pipe	A	L	H	D	Stroke	max. bar	kg
1 1/2"	38,1 x 1,65	69	100	352	110	42	13	
2"	50,8 x 1,65	84	100	358	110	42	8,5	25
2 1/2"	63,5 x 1,65	93	100	394	136	45	9	26
3"	76,2 x 1,65	107	125	436	174	46	10	39
4"	101,6 x 2,11	132	150	450	174	46	7	



REGOM INSTRUMENTS s.r.o.

Brabcova 1159 / 2

147 00 Praha 4

CZECH REPUBLIC

Tel: +420 241 402 206

Fax: +420 241 400 290

Mail: regom@regom.cz

Skype: regom-office

www.regom.cz

Copyright© 2008 REGOM INSTRUMENTS s.r.o.

Bez souhlasu REGOM INSTRUMENTS s.r.o. není dovoleno texty či obrazové materiály modifikovat, kopírovat, distribuovat, přenášet, zobrazovat, reprodukovat, publikovat, nebo pomocí nich vytvářet pozměněné materiály.

www.regom.com